



Model DML-101

# Wind Vane/Anemometer



## 【Features】

-  Light and easy handling
-  Very clear digital display
-  Suitable for severe environment

## 【Specifications】

### ■ Wind speed/direction transmitter

Type : Propeller  
 Wind speed signal transmitter : Pulse type  
 Wind direction signal transmitter : Potentiometer (10° ~ 350° )  
 Minimum detectable speed : 1 m/s or less  
 Wind speed resistance : 90 m/s (in wind tunnel tests)  
 Measurement range : Wind speed 2-70 m/s  
 Wind direction : All directions  
 Allowable distance for remote operation : 100 m max. (for 0.3x6 wire cable)  
 Ambient temperature : -20 to +50°C  
 Weight : Approx. 1kg  
 Coating color : White  
 Material : Fiberglass reinforced polycarbonate resin

### ■ Wind speed/direction indicator

Wind speed indicator : LED, 3-digit digital meter (height : 12mm)  
 Wind direction indicator : LED  
 16 direction divisional display meter (dimensions : 5x5 mm)  
 Display speed range : 0 to 99.9 m/s  
 Accuracy of measured speed : ±0.5m/s at 10m/s or less  
 ±5% at more than 10m/s  
 Accuracy of measured direction : ±5 degrees  
 Ambient temperature : - 10 to + 40°C  
 Illumination control : The illumination is controlled with a step-less control dial.  
 Power source : 100V、220V \* 1 AC 50/60Hz, or 12V DC, 24V DC (\* 1 : Please specify)  
 Weight : Approx. 1.5kg  
 Coating color : White  
 Material : Polycarbonate resin  
 Type of installation : The indicator is installed on the wall or table via a common mount stand

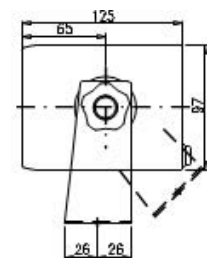
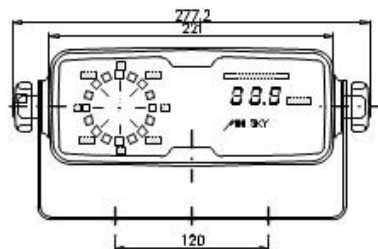
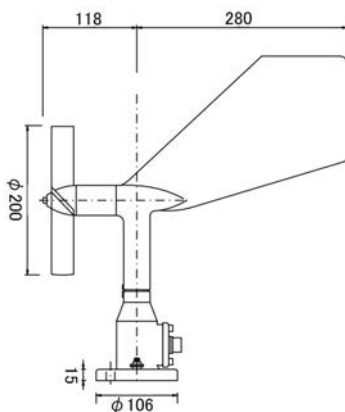

\*The specifications in this catalog may be changed without prior notice to incorporate improvements.



**KOSHIN DENKI KOGYO CO., LTD.**

Head Quarters, Meteorological Instruments Division

URL: <http://www.koshindenki.com>

1-20-19 Jiyugaoka, Meguro-ku, Tokyo 152-0035

TEL: +81-3-3717-0101 FAX: +81-3-3718-0101

### Sendai Factory

51-1 Sakaino Aza Hayama, Akiu-Cho, Taihaku-ku, Sendai-City 982-0242

TEL: +81-22-397-2121 FAX: +81-22-397-2323



**KOSHIN DENKI KOGYO CO., LTD.**