

DC Motor 22 x 48
1.13.078.0XX

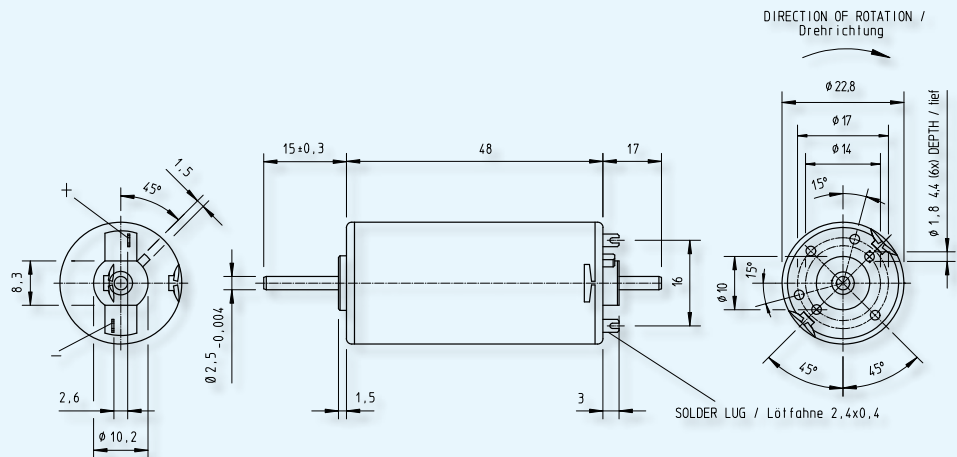

■ Type / Baureihe 1.13.078.XXX

011

012

Characteristics*	Nenndaten*				
Rated voltage	Nennspannung	U/V	V	12	24
Rated power	Nennleistung	P_N	W	4.3	4.3
Rated torque	Nenn Drehmoment	T_N/M_N	Ncm	1.0	1.0
Rated speed	Nenn Drehzahl	n_N	rpm/min ⁻¹	4000	4000
Rated current	Nennstrom	I_N	A	0.70	0.35

No load characteristics*	Leerlaufdaten*				
No load speed	Leerlauf Drehzahl	n_0	rpm/min ⁻¹	5900	5900
No load current	Leerlaufstrom	I_0	A	0.1	0.05

Stall characteristics*	Anlaufdaten*				
Stall torque	Anlaufmoment	T_s/M_H	Ncm	3.1	3.0
Stall current	Anlaufstrom	I_s/I_H	A	1.8	0.9

Performance characteristics*	Leistungsdaten*				
max. Output power	max. Abgabeleistung	P_{max}	W	5.0	5.0
max. Constant torque	max. Dauer Drehmoment	T_{max}/M_{max}	Ncm	0.60	0.60

Motor parameters*	Motorparameter*				
Weight	Gewicht	G	g	78	78
Rotor inertia	Läuferträgheitsmoment	J	gcm ²	8.1	8.1
Terminal resistance	Anschlusswiderstand	R	Ohm	6.2	27
Inductance	Induktivität	L	mH	8.0	16
Mech. time constant	Mech. Zeitkonstante	τ_m	ms	18	19
Electr. time constant	Elektr. Zeitkonstante	τ_e	ms	1.3	0.8
Speed regulation constant	Drehzahregelkonstante	R_m	rpm/Ncm	1840	1980
Torque constant	Drehmomentkonstante	k_t/k_M	Ncm/A	1.8	3.5
Thermal resistance	Thermischer Widerstand	R_{th}	K/W	34	34
Thermal time constant	Thermische Zeitkonstante	τ_{th}	min	6.0	6.0
Axial play	Axialspiel		mm	0.05 - 0.6	0.05 - 0.6
Direction of rotation	Drehrichtung			bidirectional / bidirektional	

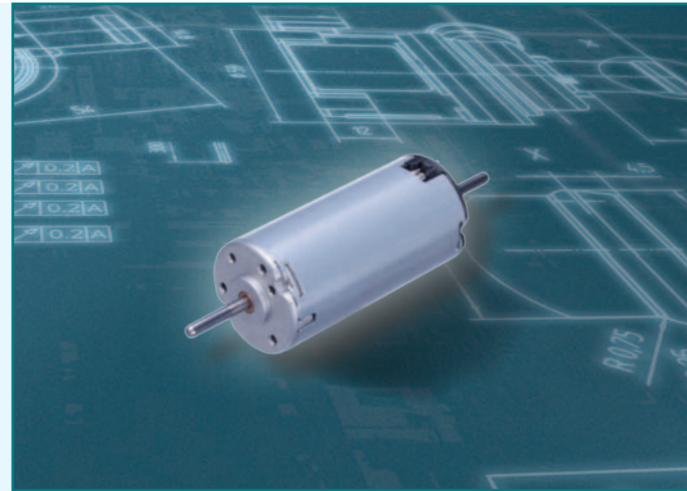
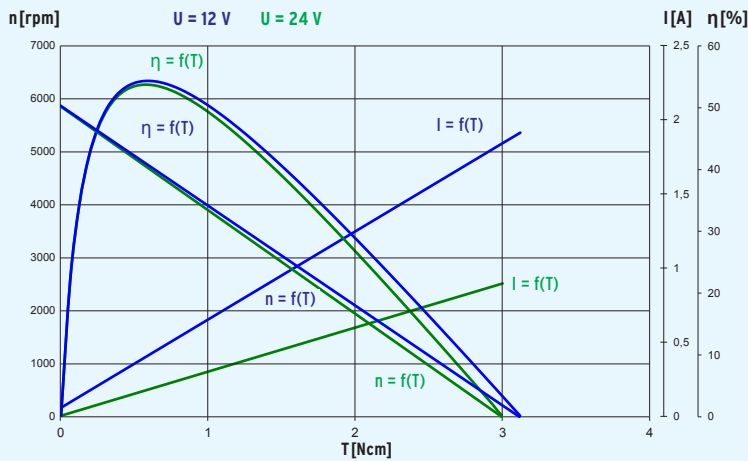

Design	
Commutator	Copper/3-segments
RFI Protection	Suppression disk; 2 capacitors
Insulation class	Winding F, otherwise A
Protection class	IP20
Commutation	Carbon brushes
Armature	straight slot
Magnet system	Permanent magnets, 2-pole
Bearings	2 sintered bronze bearings
Housing	Steel, corrosion protected
End shields	brush end plastic drive end zinc die-cast
Typical life expectancy	400 h

Aufbau	
Kollektor	Kupfer/3-teilig
Grundentstörung	Entstörscheibe; 2 Kondensatoren
Isolierstoffklasse	Wicklung F, ansonsten A
Schutzart	IP20
Kommutierung	Kohlenbürsten
Anker	gerade Nut
Magnetsystem	Permanentmagnete, 2-polig
Motorlager	2 ölgetränkte Sinterbronzelager
Gehäuse	Stahl, korrosionsgeschützt
Lagerschilde	kollektorseitig Kunststoff abtriebsseitig Zinkdruckguss
Typische Lebensdauer	400 h

Operational conditions*	Einsatzbedingungen*			
Temperature range	Temperaturbereich	T	°C	-10 - +70
Axial force	Axialkraft	F _A	N	5
Radial force, 10 mm from mounting surface	Radialkraft, 10 mm ab Anschraubfläche	F _R	N	10

* at 25 °C

* bezogen auf 25 °C

Customized Bühler drives / Maßgeschneiderte Bühler Antriebe

- ▶ Variants: p. 84 / Varianten: S. 84
- ▶ Customer specific developments: p. 88 / Kundenspezifische Entwicklungen: S. 88

Application Examples / Applikationsbeispiele

- ▶ Building automation / Gebäudeautomation