

## DC Motor 24 flat 1.16.011.5XX

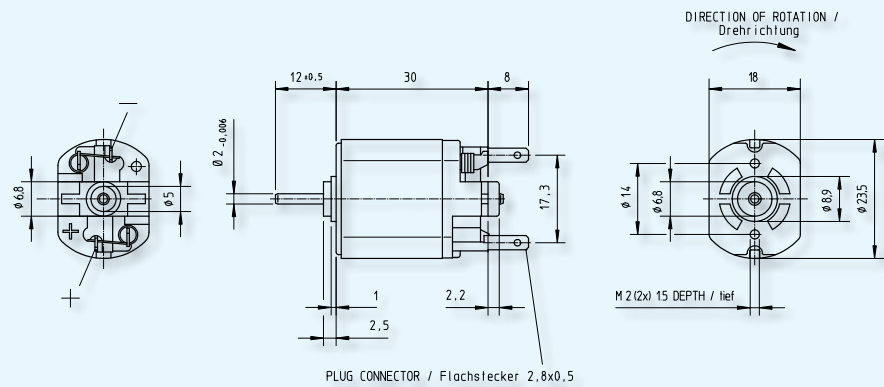

■ Type / Baureihe 1.16.011.XXX

532

545

Characteristics*	Nenndaten*				
Rated voltage	Nennspannung	U/V	V	12	24
Rated power	Nennleistung	P <sub>N</sub>	W	2.1	2.0
Rated torque	Nenn Drehmoment	T <sub>N</sub> /M <sub>N</sub>	Ncm	0.4	0.4
Rated speed	Nenn Drehzahl	n <sub>N</sub>	rpm/min <sup>-1</sup>	5000	4800
Rated current	Nennstrom	I <sub>N</sub>	A	0.35	0.18

No load characteristics*	Leerlaufdaten*				
No load speed	Leerlauf Drehzahl	n <sub>0</sub>	rpm/min <sup>-1</sup>	7400	7600
No load current	Leerlaufstrom	I <sub>0</sub>	A	0.05	0.03

Stall characteristics*	Anlaufdaten*				
Stall torque	Anlaufmoment	T <sub>S</sub> /M <sub>H</sub>	Ncm	1.2	1.1
Stall current	Anlaufstrom	I <sub>S</sub> /I <sub>H</sub>	A	0.9	0.4

Performance characteristics*	Leistungsdaten*				
max. Output power	max. Abgabeleistung	P <sub>max</sub>	W	2.4	2.2
max. Constant torque	max. Dauer Drehmoment	T <sub>max</sub> /M <sub>max</sub>	Ncm	0.24	0.23

Motor parameters*	Motorparameter*				
Weight	Gewicht	G	g	35	35
Rotor inertia	Läuferträgheitsmoment	J	gcm <sup>2</sup>	3.2	3.2
Terminal resistance	Anschlusswiderstand	R	Ohm	13	61
Inductance	Induktivität	L	mH	17	37
Mech. time constant	Mech. Zeitkonstante	τ <sub>m</sub>	ms	22	22
Electr. time constant	Elektr. Zeitkonstante	τ <sub>e</sub>	ms	1.3	0.65
Speed regulation constant	Drehzahregelkonstante	R <sub>m</sub>	rpm/Ncm	6300	7000
Torque constant	Drehmomentkonstante	k <sub>t</sub> /k <sub>M</sub>	Ncm/A	1.4	2.8
Thermal resistance	Thermischer Widerstand	R <sub>th</sub>	K/W	41	41
Thermal time constant	Thermische Zeitkonstante	τ <sub>th</sub>	min	8.0	8.0
Axial play	Axialspiel		mm	0.05 - 0.6	0.05 - 0.6
Direction of rotation	Drehrichtung			bidirectional / bidirektional	

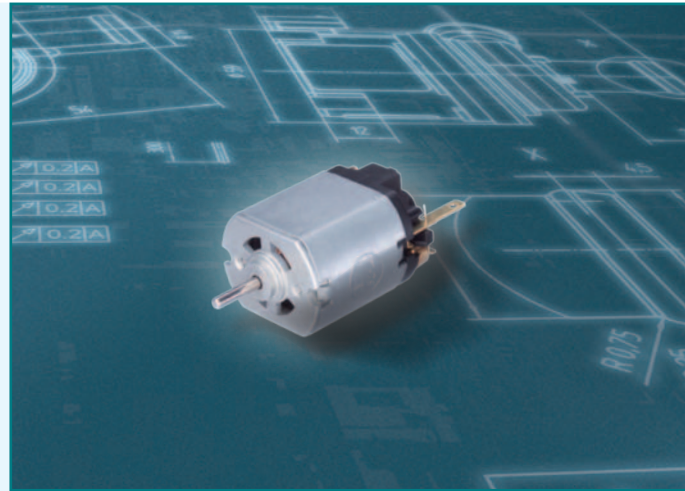
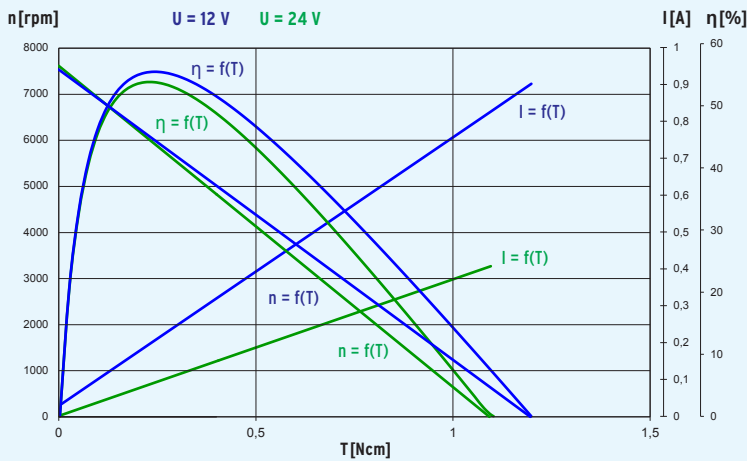

Design	
Commutator	Copper/3-segments
RFI Protection	Suppression disk
Insulation class	Winding F, otherwise A
Protection class	IP20
Commutation	Carbon brushes
Armature	straight slot
Magnet system	Permanent magnets, 2-pole
Bearings	2 sintered bronze bearings
Housing	Steel, corrosion protected
End shields	brush end plastic drive end zinc die-cast
Typical life expectancy	600 h

Aufbau	
Kollektor	Kupfer/3-teilig
Grundentstörung	Entstörscheibe
Isolierstoffklasse	Wicklung F, ansonsten A
Schutzart	IP20
Kommutierung	Kohlenbürsten
Anker	gerade Nut
Magnetsystem	Permanentmagnete, 2-polig
Motorlager	2 ölgetränkte Sinterbronzelager
Gehäuse	Stahl, korrosionsgeschützt
Lagerschilde	kollektorseitig Kunststoff abtriebsseitig Zinkdruckguss
Typische Lebensdauer	600 h

Operational conditions*	Einsatzbedingungen*			
Temperature range	Temperaturbereich	T	°C	-10 - +70
Axial force	Axialkraft	$F_A$	N	2
Radial force, 5 mm from mounting surface	Radialkraft, 5 mm ab Anschraubfläche	$F_R$	N	5

\* at 25 °C

\* bezogen auf 25 °C

### Customized Bühler drives / Maßgeschneiderte Bühler Antriebe

- ▶ Variants: p. 84 / Varianten: S. 84
- ▶ Customer specific developments: p. 88 / Kundenspezifische Entwicklungen: S. 88

### Application Examples / Applikationsbeispiele

- ▶ Paper handling / Papierverarbeitende Industrie
- ▶ Vending machines/Verkaufsautomaten
- ▶ Banking machines/Geldausgabeautomaten

## DC Motor 24 flat 1.16.011.5XX

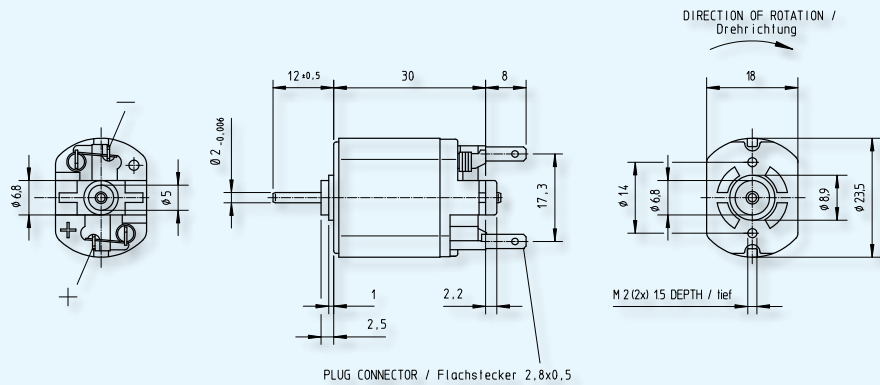

■ Type / Baureihe 1.16.011.XXX

501

502

Characteristics*	Nenndaten*				
Rated voltage	Nennspannung	U/V	V	12	24
Rated power	Nennleistung	$P_N$	W	3.5	3.6
Rated torque	Nenn Drehmoment	$T_N/M_N$	Ncm	0.5	0.5
Rated speed	Nenn Drehzahl	$n_N$	rpm/min <sup>-1</sup>	6800	6900
Rated current	Nennstrom	$I_N$	A	0.56	0.28

No load characteristics*	Leerlaufdaten*				
No load speed	Leerlauf Drehzahl	$n_0$	rpm/min <sup>-1</sup>	10200	10200
No load current	Leerlaufstrom	$I_0$	A	0.08	0.04

Stall characteristics*	Anlaufdaten*				
Stall torque	Anlaufmoment	$T_s/M_H$	Ncm	1.5	1.6
Stall current	Anlaufstrom	$I_s/I_H$	A	1.5	0.8

Performance characteristics*	Leistungsdaten*				
max. Output power	max. Abgabeleistung	$P_{max}$	W	4.0	4.2
max. Constant torque	max. Dauer Drehmoment	$T_{max}/M_{max}$	Ncm	0.28	0.29

Motor parameters*	Motorparameter*				
Weight	Gewicht	G	g	35	35
Rotor inertia	Läuferträgheitsmoment	J	gcm <sup>2</sup>	3.2	3.2
Terminal resistance	Anschlusswiderstand	R	Ohm	8.0	30
Inductance	Induktivität	L	mH	12	24
Mech. time constant	Mech. Zeitkonstante	$\tau_m$	ms	22	22
Electr. time constant	Elektr. Zeitkonstante	$\tau_e$	ms	1.6	0.8
Speed regulation constant	Drehzahregelkonstante	$R_m$	rpm/Ncm	6700	6500
Torque constant	Drehmomentkonstante	$k_t/k_M$	Ncm/A	1.05	2.1
Thermal resistance	Thermischer Widerstand	$R_{th}$	K/W	41	41
Thermal time constant	Thermische Zeitkonstante	$\tau_{th}$	min	8.0	8.0
Axial play	Axialspiel		mm	0.05 - 0.6	0.05 - 0.6
Direction of rotation	Drehrichtung			bidirectional / bidirektional	

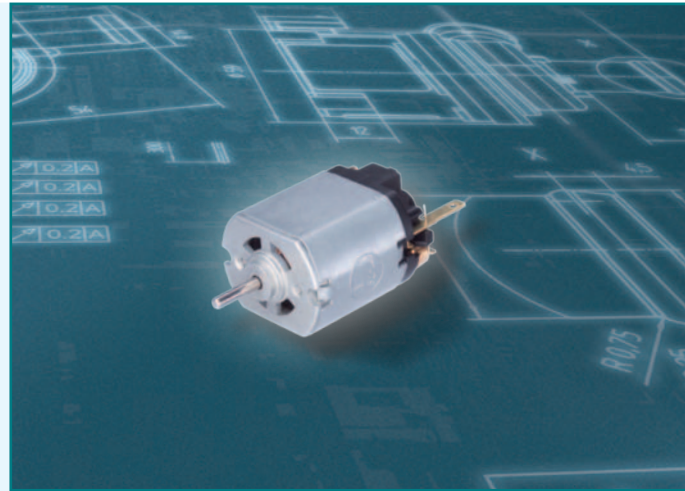
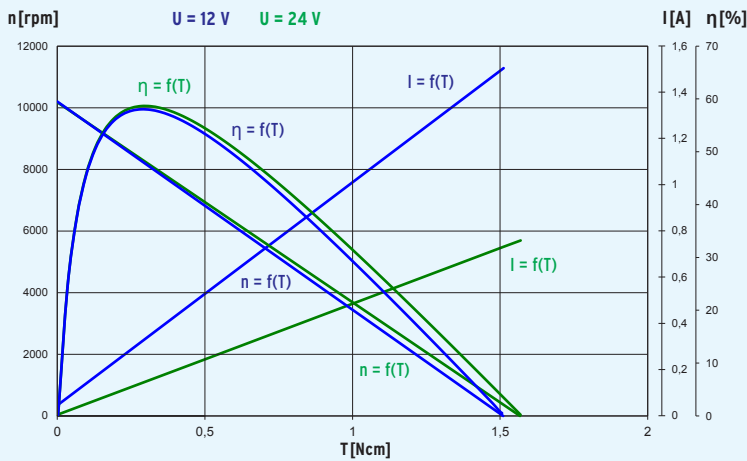

Design	
Commutator	Copper/3-segments
RFI Protection	Suppression disk
Insulation class	Winding F, otherwise A
Protection class	IP20
Commutation	Carbon brushes
Armature	straight slot
Magnet system	Permanent magnets, 2-pole
Bearings	2 sintered bronze bearings
Housing	Steel, corrosion protected
End shields	brush end plastic drive end zinc die-cast
Typical life expectancy	600 h

Aufbau	
Kollektor	Kupfer/3-teilig
Grundentstörung	Entstörscheibe
Isolierstoffklasse	Wicklung F, ansonsten A
Schutzart	IP20
Kommutierung	Kohlenbürsten
Anker	gerade Nut
Magnetsystem	Permanentmagnete, 2-polig
Motorlager	2 ölgetränkte Sinterbronzelager
Gehäuse	Stahl, korrosionsgeschützt
Lagerschilde	kollektorseitig Kunststoff abtriebsseitig Zinkdruckguss
Typische Lebensdauer	600 h

Operational conditions*	Einsatzbedingungen*			
Temperature range	Temperaturbereich	T	°C	-10 - +70
Axial force	Axialkraft	$F_A$	N	2
Radial force, 5 mm from mounting surface	Radialkraft, 5 mm ab Anschraubfläche	$F_R$	N	5

\* at 25 °C

\* bezogen auf 25 °C

### Customized Bühler drives / Maßgeschneiderte Bühler Antriebe

- ▶ Variants: p. 84 / Varianten: S. 84
- ▶ Customer specific developments: p. 88 / Kundenspezifische Entwicklungen: S. 88

### Application Examples / Applikationsbeispiele

- ▶ Paper handling / Papierverarbeitende Industrie
- ▶ Vending machines / Verkaufsautomaten
- ▶ Banking machines / Geldausgabeautomaten